

# **MUELLER<sup>®</sup>**

## **HORIZONTAL AGITATOR ASSEMBLY**

### **(PATENT NO. US 6,193,409 B1)**

## **INSTALLATION MANUAL**



**Part No. 9828450**

**Effective April 5, 2000**

**Revised March 12, 2008**

**MUELLER<sup>®</sup>**  
PROCESSING SYSTEMS AND EQUIPMENT



**MUELLER® HORIZONTAL AGITATOR ASSEMBLY  
(PATENT NO. US 6,193,409 B1)  
INSTALLATION MANUAL**

Table of Contents

1.0	Horizontal Agitator Assembly Installation Instructions .....	1
2.0	Horizontal Agitator Assembly Schematic .....	5
3.0	Suggested Routine Maintenance .....	6
4.0	Parts List .....	7
5.0	Side Elevation View .....	8
6.0	Bill of Materials .....	8
7.0	Detail "A" .....	9
8.0	Reference Drawing, No. GD02186 .....	10

# MUELLER® HORIZONTAL AGITATOR ASSEMBLY (PATENT NO. US 6,193,409 B1) INSTALLATION MANUAL

## 1.0 Installation Instructions

1. Obtain the parts from the parts box and verify that the quantities and part numbers match the bill of materials.
2. Remove the plastic protective caps, bolt, washer, and square key from the hollow output shaft of the gearmotor. (The loose bolt, washer, and protective caps are not required for assembly; however, the square key must be retained for use on prop shaft assembly.)



**IMPORTANT: The snap ring inside the gear reducer hollow bore must be installed in the groove at the opposite end from the flange. Snap ring pliers can be used to remove and/or install snap ring. The snap ring is designed as a stop for the agitator shaft. Without the snap ring properly installed, incorrect compression of the spring and improper alignment of the O-rings will occur, which may result in severe damage. If the snap ring is missing, contact Mueller before installing the agitator assembly. DO NOT RUN THE AGITATOR WITHOUT THE SNAP RING IN PLACE. See Figure 1.**

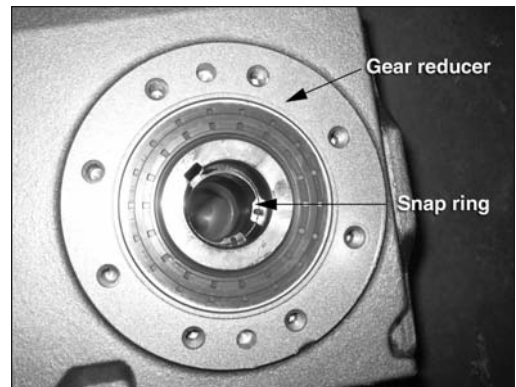

Figure 1

3. To mount the gearmotor to the housing, insert a cap screw (item 9) into one of the four holes on the flange with the cap end facing away from the gearmotor. Slide the lock washer (item 11) onto the end of the cap screw, and then screw the hex nut (item 10) onto the end over it. Repeat for the other three holes. See Figure 2.
4. If the agitator assembly kit includes a Eurodrive gearmotor, remove the four plastic plugs from the gear reducer housing around the hollow bore.
5. With the tabs of the cover mounting clip (item 16) parallel to the length of the gearmotor, secure it in place onto the gear reducer with the two cap screws (item 18) and spacers (item 19, only used for Nord gearmotor). See Figure 3.

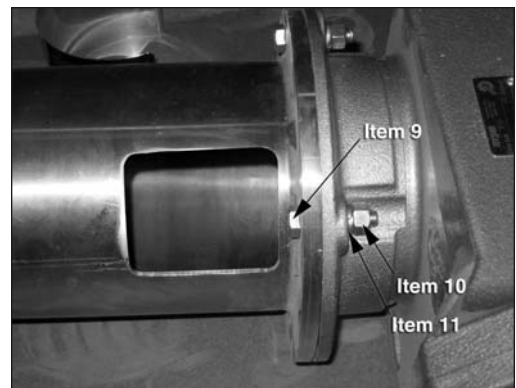

Figure 2

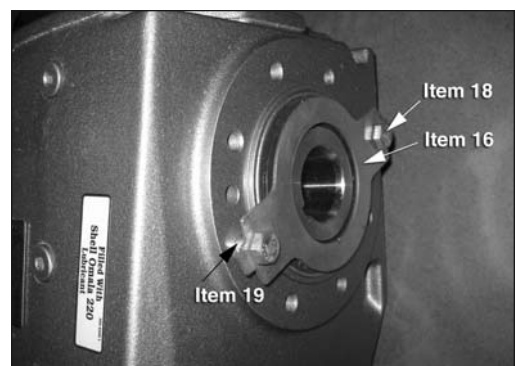

Figure 3

- Install one of the O-rings (item 7) in the groove on the agitator shaft closer to the prop, then cover the exposed surface of the O-ring with a thin coating of food-grade lubricant, such as NEVER-SEEZ® White Food Grade or Loctite® Food Grade Anti-Seize. See Figure 4.

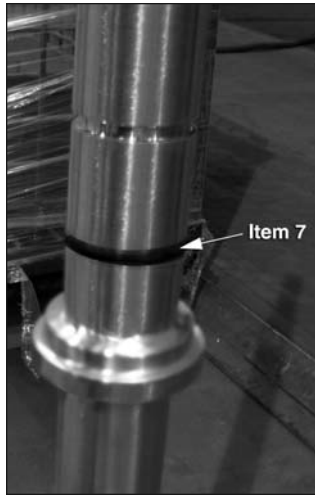

Figure 4

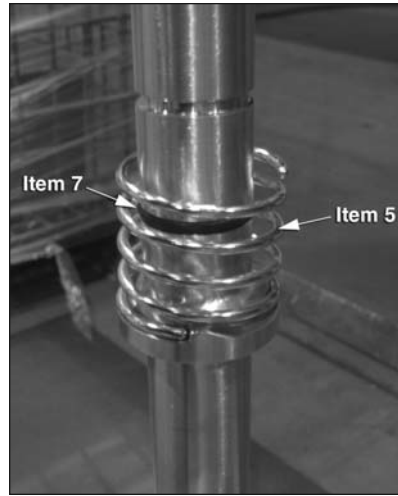

Figure 5

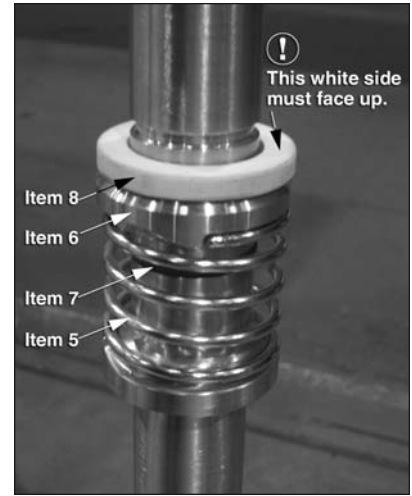

Figure 6

- Slide the spring (item 5) onto the shaft, abutting the end of the spring against the outer ledge on the shaft; and follow it with the stainless steel rotary seal (item 6), matching the opposing end of the spring to the ledge on the rotary seal. The gasket seal (item 8) should be slid onto the shaft with the black silicon carbide side facing the rotary seal, resting the gasket seal on the opposing end of the rotary seal to the spring. See Figures 5 and 6.



**IMPORTANT: Failure to install the black silicon carbide face of the gasket seal against the stainless steel rotary seal will damage the housing sealing surface. See Figure 7.**



Figure 7

- Install the second O-ring in the groove of the agitator shaft further from the prop. (See Section 3.0, "Suggested Routine Maintenance" for more information on this O-ring.) See Figure 8.

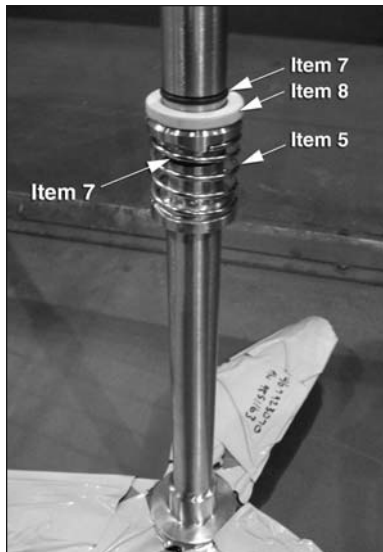

Figure 8

- Install the square key in the slot just below the threaded end of the agitator shaft. On the area where the key and agitator shaft will contact the hollow output shaft of the gear reducer, apply a liberal coating of food-grade lubricant, such as NEVER-SEEZ® White Food Grade or Loctite® Food Grade Anti-Seize. See Figure 9.

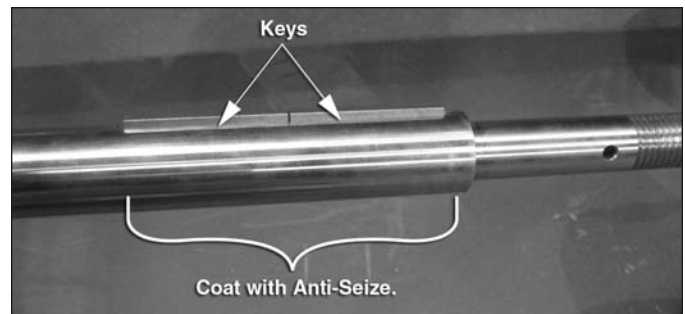

Figure 9

- Starting with the entire agitator shaft (Item 4) inside of the tank, slide the threaded end of the agitator shaft through the shell of the tank and into the housing (Item 1), making sure to align the key on the agitator shaft with the key slot on the hollow gearmotor (Item 3) output shaft. Stop pushing the agitator shaft through when the shoulder of the shaft pushes against the snap ring inside the gear reducer. (At this point, the shaft will not be able to be pushed farther without deforming the metal.) See Figures 10 and 11.

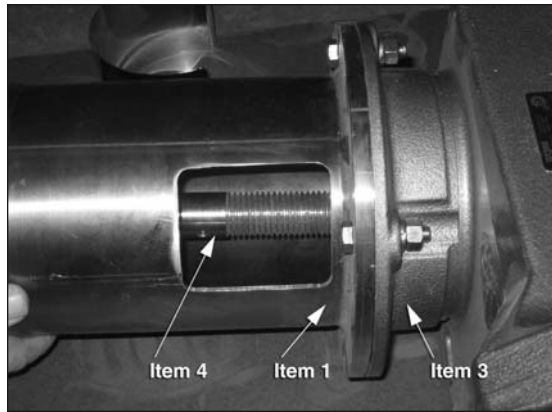

Figure 10

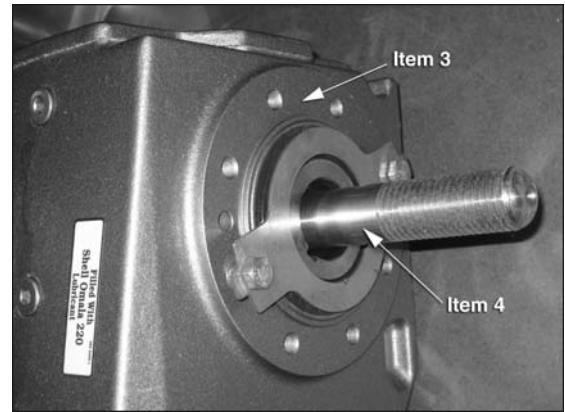

Figure 11

- Insert the pin (item 14) into the hole in the side of the threaded end of the shaft. Slide the nylon spacer (item 13) over the shaft and pin to hold the pin in this position. See Figures 12 and 13.

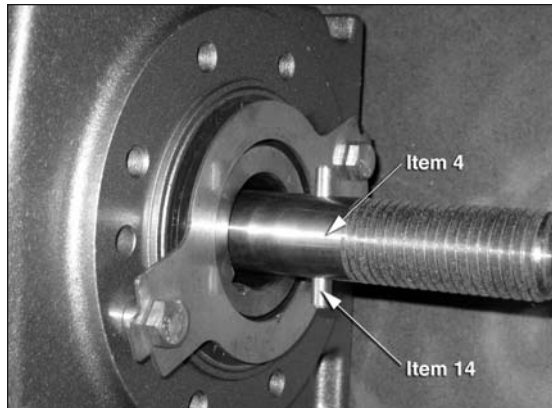

Figure 12

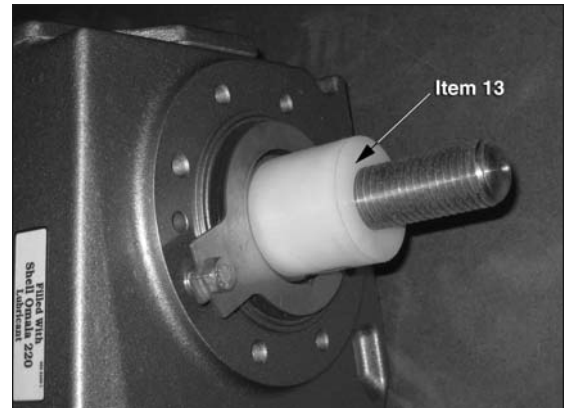

Figure 13

- Slide the nylon locking knob (item 12), unthreaded end first, onto the threaded end of the shaft until the shaft comes into contact with the threading on the locking knob. Screw the locking knob onto the shaft until it comes into contact with the nylon spacer. The locking knob must be tightened and kept tight. (A vise grip or channel-lock pliers may be used; however, over-tightening will damage the knob and possibly the seal and/or snap ring as well.) See Figure 14.

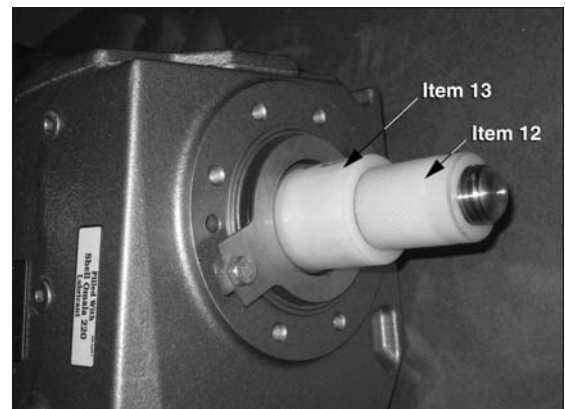

Figure 14

13. Carefully squeeze the sides of the assembly shield (item 15) and place the assembly shield onto the tabs, aligning the slots of the assembly shield with the tabs of the mounting clip, to fully cover the threading of the agitator shaft and knob. See Figure 15.

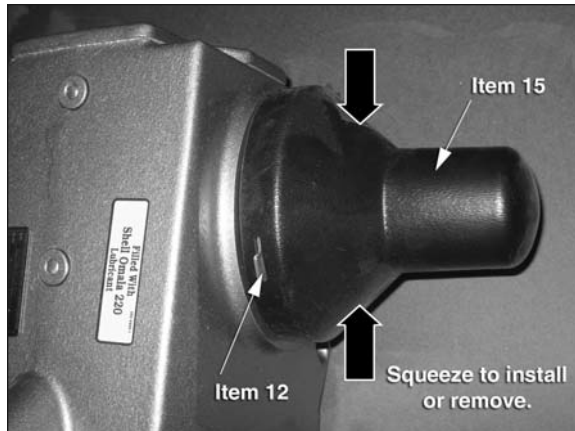

Figure 15



Figure 16

14. Place the inspection cover (item 17) over the housing inspection port and snap into place to complete the installation. See Figure 16.



**IMPORTANT: The agitator must not be operated with the prop partially submerged or with the product level within one prop diameter above the agitator. Operating the agitator under these conditions may result in the agitator assembly and/or vessel being severely damaged. See Figure 17.**

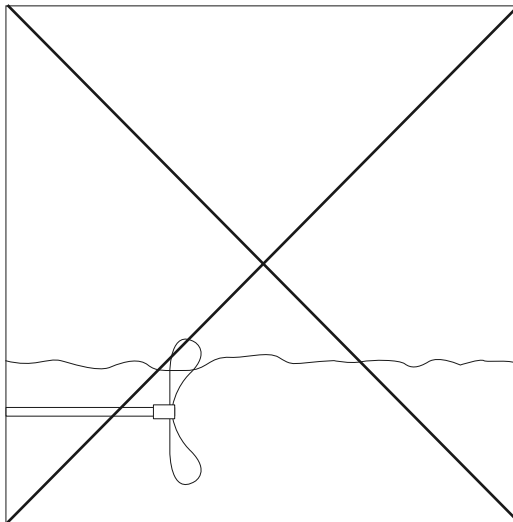
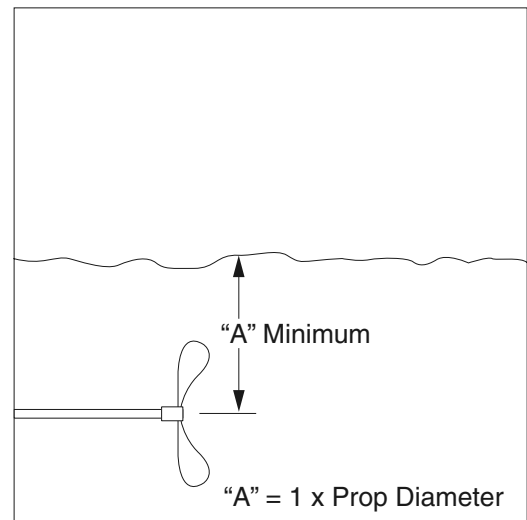
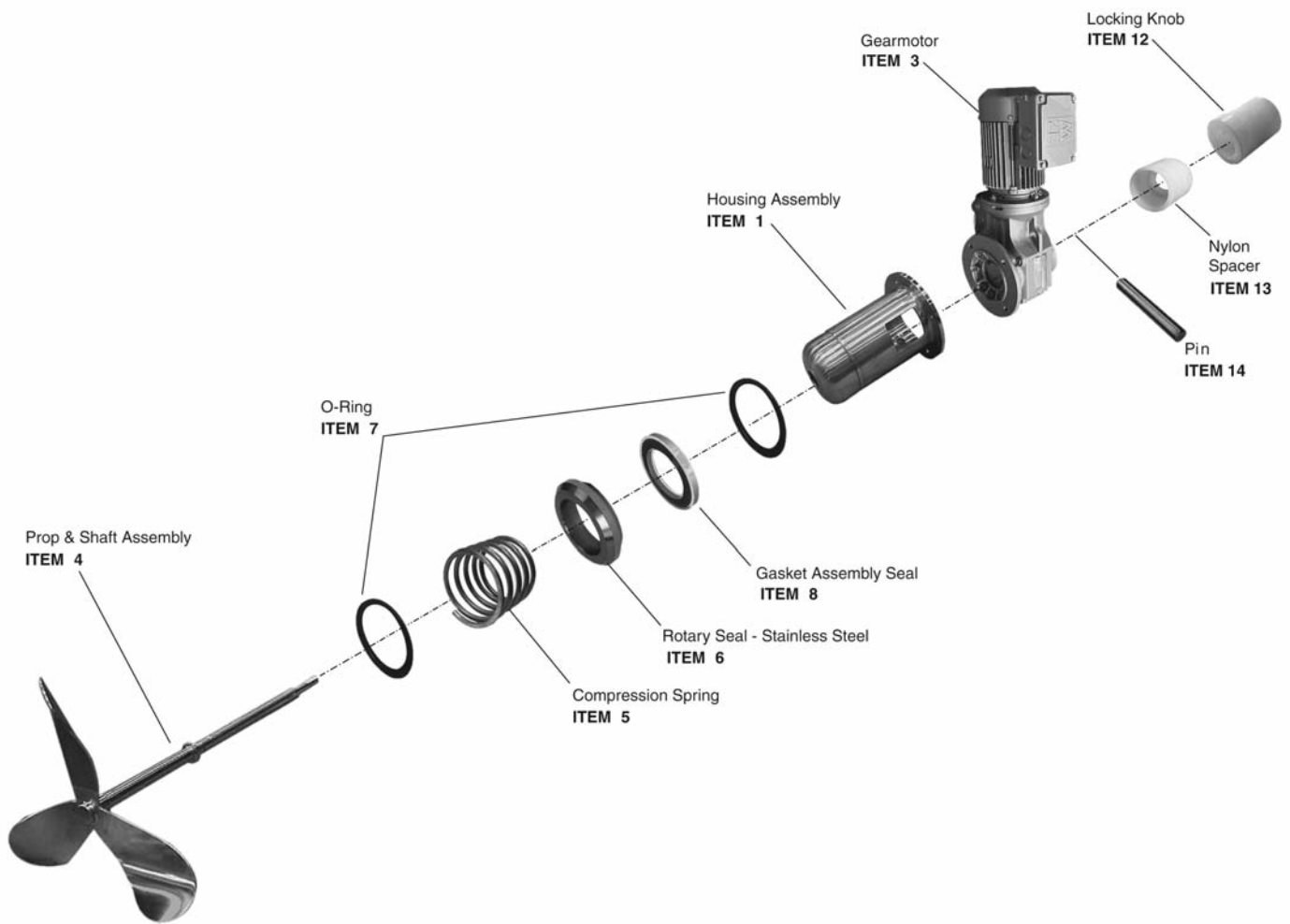

Figure 17



## 2.0 Horizontal Agitator Assembly Schematic



### 3.0 Suggested Routine Maintenance

**NOTE:** Refer to Section 1.0, "Installation Instructions" for detailed information when disassembling and/or re-installing agitator assembly.

1. The agitator seal assembly should be inspected periodically and worn or damaged items should be immediately replaced with authentic Mueller spare parts.



**IMPORTANT: The inspection frequency is dependent upon operating environment and conditions, cleaning agents and practices, and many other factors beyond the control of Paul Mueller Company. It is the purchaser's responsibility to determine an inspection frequency appropriate for their unique operating conditions.**

2. To inspect the stainless steel rotary seal (item 6) and gasket seal (item 8), carefully squeeze the sides of the assembly shield (item 15) to remove it from the tabs of the mounting clip (item 16), loosen the locking knob (item 12) and push the agitator shaft into the tank until the pin (item 14) pushes against the gear reducer; the O-ring (item 7) on the agitator shaft inside the housing will push on the gasket seal and push the seal out of position for inspection and/or replacement.



**IMPORTANT: Using any other procedure to remove the gasket seal (item 8) may result in damaging or breaking the seal.**

3. Visually inspect the face of the seal housing (item 1) for possible grooves; if the housing face is damaged, contact Mueller Field Service for resurfacing support.

**NOTE:** If it is necessary to order replacement parts, please indicate the serial number of the vessel and the type of gear reducer in place.

















4. If the gasket seal (item 8) and/or rotary seal (item 6) need to be replaced, it is suggested to change the shaft O-rings (item 7) as well.
5. When installing a new gasket seal, make sure the gasket seal (item 8) is slid onto the shaft with the black silicon carbide side facing the rotary seal (item 6), resting the gasket seal on the opposing end of the rotary seal to the spring.
6. Check to make sure the snap ring inside of the gear reducer hollow bore is installed in the groove at the opposite end from the flange. The snap ring is designed as a stop for the agitator shaft.



**IMPORTANT: Without the snap ring properly installed, incorrect compression of the spring and improper alignment of the O-rings will occur, which may result in severe damage. If the snap ring is missing, contact Paul Mueller Company before re-installing the agitator assembly. DO NOT RUN THE AGITATOR WITHOUT THE SNAP RING IN PLACE.**

7. Prior to re-installation, lubricate the hollow output shaft of gear reducer, key, and agitator shaft making contact with hollow shaft of gear reducer with a liberal coating of food-grade lubricant, such as NEVER-SEEZ® White Food Grade, Loctite® Food Grade Anti-Seize, etc.
8. The locking knob must be re-tightened and kept tight. (A vise grip or channel-lock pliers may be used; however, over-tightening will damage the knob and possibly the seal and/or snap ring as well.)

## 4.0 Parts List

Item No.	Picture of Part	Part No.	Description	No. Required
1		9825979	Housing Assembly	1
3		"C"	Gearmotor	1
4		"J"	Prop & Shaft Assembly	1
5		9825993	Compression Spring	1
6		9850421	Rotary Seal, Stainless Steel	1
7		9850414	O-Ring, "Parker"	2
8		9825982	Gasket Assembly Seal	1
9		3200012	Cap Screw	4
10		30532	Hex Nut	4
11		30535	Lock Washer	4
12		9806423	Locking Knob	1
13		9826757	Nylon Spacer	1
14		9826758	Pin	1
15A		9826759	Shield Assembly - Eurodrive	1
15B		9851158	Shield Assembly - Nord	1
16A		9828974	Mounting Clip - Eurodrive	1
16B		9851159	Mounting Clip - Nord	1
17		9828412	Inspection Port Cover	1
18A		9825669	Cap Screw - Eurodrive	2
18B		9851415	Cap Screw - Nord	2
19		9851396	Spacer - Nord	2

## 5.0 Side Elevation View

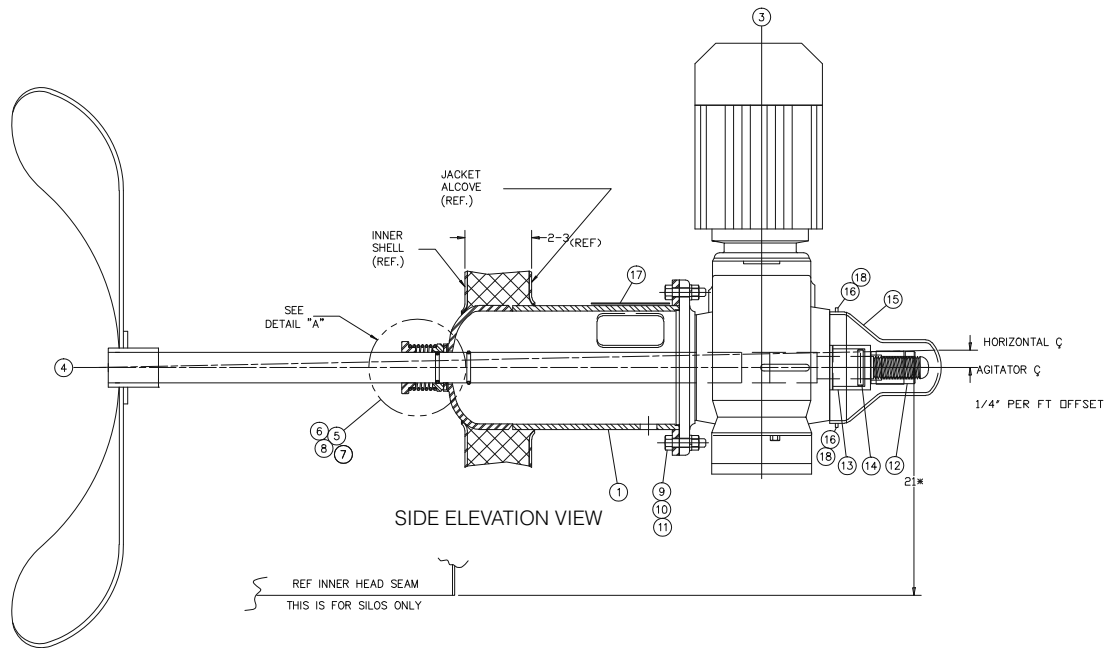

## 6.0 Bill of Materials

ITEM	QTY	PART NO.	DESCRIPTION
	1	"A"	AGITATOR, HORIZONTAL ASSEMBLY, 1.375" OD W/ "D" HP & "G" RPM
1	1	9825979	HOUSING ASSEMBLY, AGITATOR, 5.0" SCH 40, 10.375" LG 304 S/S
2	1	"B"	AGITATOR COMPONENT, HORIZONTAL, W/O HOUSING "D" HP & "G" RPM 304 S/S
3A	1	"C"	GEARMOTOR, "D" HP, "G" RPM OUTPUT, "H" VOLTAGE, TEFC, EURODRIVE KAF47DT, "F" RATIO, "E" MOTOR RPM, SEVERE DUTY WASHDOWN POS M4A CONDUIT BOX @270°
3B	1	"C"	GEARMOTOR, "D" HP, "G" RPM OUTPUT, "H" VOLTAGE, TEFC, NORD, SK92672AFB, "F" RATIO, "E" MOTOR RPM, SEVERE DUTY WASHDOWN H3 POS TB2 CHI, FLANGE ALT DIA = 7.87" SIDE "A"
4A	1	"J"	PROP & SHAFT ASSEMBLY, EURODRIVE, 1.375" SHAFT, 36.75" LG HORIZONTAL, 304 S/S
4B	1	"J"	PROP & SHAFT ASSEMBLY, NORD, 1.375" SHAFT, 38.0625" LG HORIZONTAL, 304 S/S
5	1	9825993	SPRING, COMPRESSION
6	1	9850421	ROTARY SEAL, 2.125" DIA X .538" 316 S/S
7	2	9850414	O-RING, PARKER, #2-216, NEOPRENE, FDA APPROVED, .139 CROSS SECTION
8	1	9825982	SEAL, GASKET, ASSEMBLY, 1.375" DIA, AGITATOR SHAFT .125" THK, SILICON CARBIDE W/ NEOPRENE, 70-80 DURO BONDED TO OD
9	4	3200012	SCREW, CAP, HH, .375-16NC X 18-8 S/S
10	4	30532	NUT, HEX, 375-16NC, 18-8 S/S, FINISHED
11	4	30535	WASHER, LOCK, .375", 18-8 S/S, MED SPLIT
12	1	9806423	KNOB, LOCKING, AGITATOR, 6/6 NYLON
13	1	9826757	SPACER, HORIZONTAL AGITATOR, 6/6 NYLON
14	1	9826758	PIN, .25" DIA, 1.625" LG, 304 S/S
15A	1	9826759	SHIELD ASSEMBLY, HORIZONTAL AGITATOR, EURODRIVE
15B	1	9851158	SHIELD ASSEMBLY, HORIZONTAL AGITATOR, NORD
16A	1	9828974	CLIP, MOUNTING SHIELD, 16 GA, 304 S/S, EURODRIVE
16B	1	9851159	CLIP, MOUNTING SHIELD, 16 GA, 304 S/S, NORD
17	1	9828412	COVER, INSPECTION PORT, HORIZONTAL AGITATOR, 20 GA, 304 S/S
18A	2	9825669	SCREW, CAP, M8 X 1.25 X 12 MM, LG, 18-8 S/S, EURODRIVE
18B	2	9851415	SCREW, CAP, M8 X 1.25 X 12 MM, LG, 18-8 S/S, NORD
19	2	9851396	SPACER, .5" OD, .3125" LG, NORD

## 7.0 Detail "A"

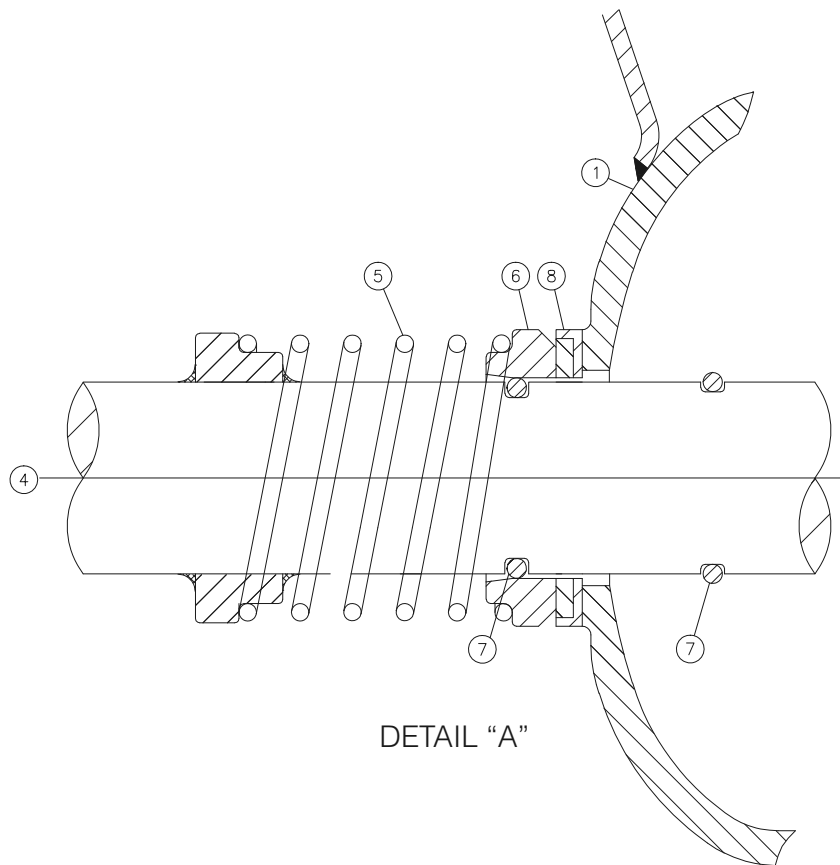

DETAIL "A"

Stock Silo Size	Prop Diameter	A	B	C	D	E	F	G	H	J	
		Assembly No.	Assembly w/o Housing	Gear Motor	HP	Motor RPM	Ratio	Output RPM	Voltage	Prop & Shaft	
5,000-8,000	23 1/2"	9826775	9826783	9826791	1	1,700	15.86:1	107	3/60/230-460V	9825986	Eurodrive
	23 1/2"	9851157	9851155	9851154	1	1,650	16.08:1	103	3/60/230-460V	9851156	Nord
10,000-15,000	27"	9826776	9826784	9826792	2	1,720	15.86:1	108	3/60/230-460V	9826798	Eurodrive
	27"	9851160	9851161	9851162	2	1,660	16.08:1	103	3/60/230-460V	9851163	Nord
20,000-60,000	23 1/2"	9825981	9825984	9825985	3	1,700	10.56:1	161	3/60/230-460V	9825986	Eurodrive
	23 1/2"	9851164	9851165	9851166	3	1,705	11.02:1	155	3/60/230-460V	9821156	Nord

# 8.0 Reference Drawing, No. GD02186

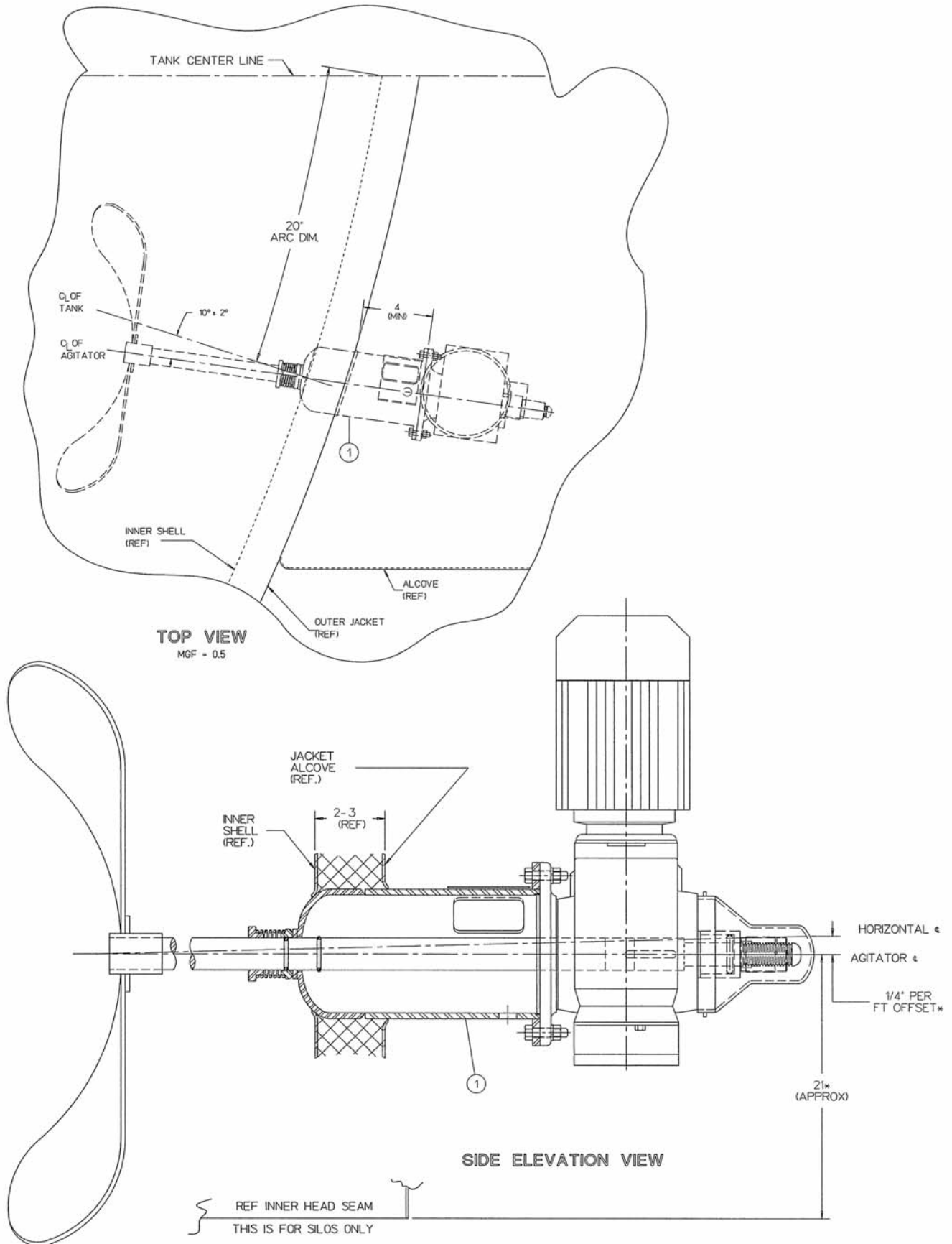

## 8.0 Reference Drawing, No. GD02186 (continued)

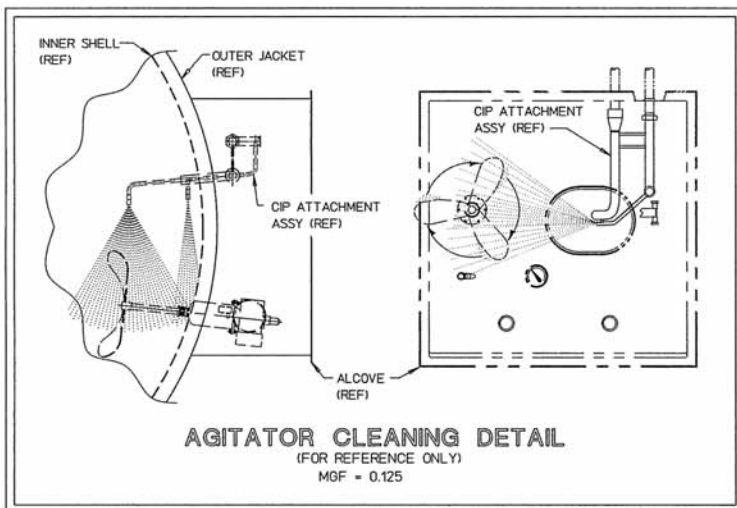
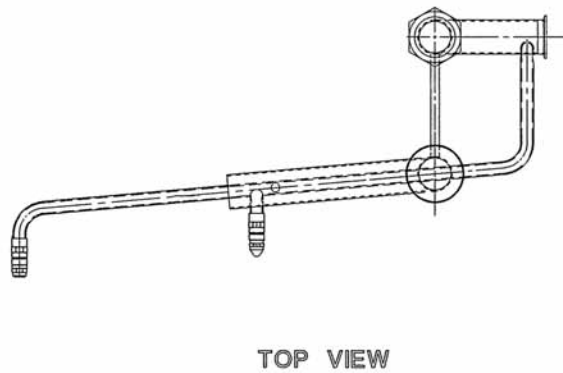
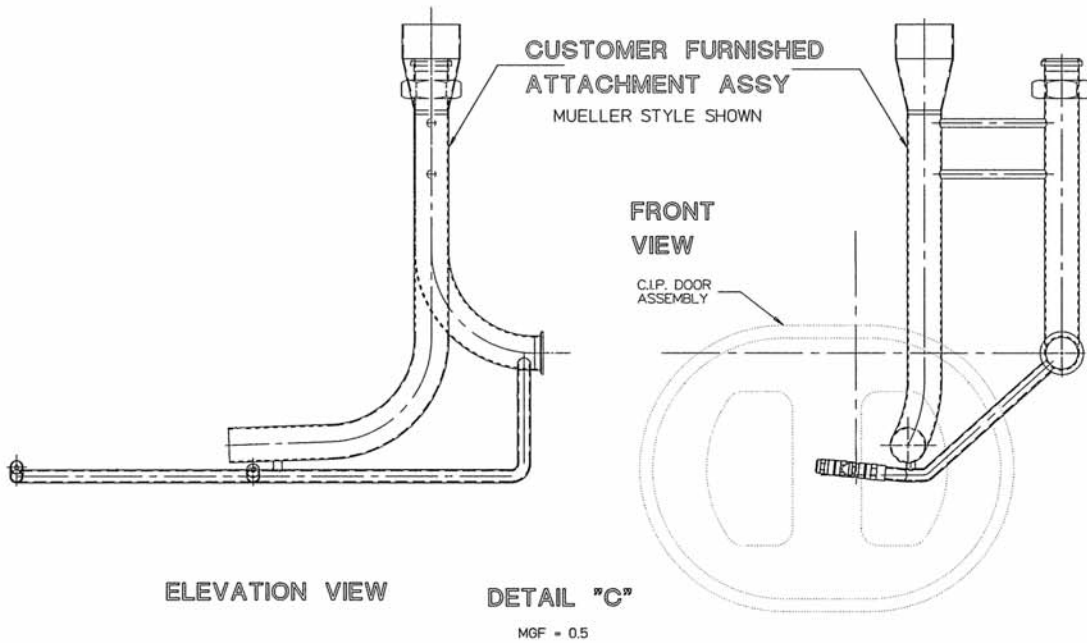

### NOTES:

1. WELDS TO BE #4 (32 RA. MAX.)
2. POLISH ALL SURFACES IN CONTACT WITH PRODUCT TO #4 MATERIAL FINISH.
3. ALL DIMENSIONS ARE IN INCHES.
4. CUSTOMER TO TAKE NECESSARY PRECAUTIONS IN WELDING HOUSING TO INNER SHELL AS TO NOT DEFORM SEAL FACE OF HOUSING.
5. STANDARD SHOP TOLERANCES APPLY UNLESS OTHERWISE NOTED.
6. PACK UNDERCUT AREA WITH FOOD GRADE NEVERSEEZ.
7. AGITATOR ASSY MEETS 3-A SANITARY STANDARD 22-07 FOR CLEAN IN PLACE SERVICE.
8. SEAL GASKET BONDING ADHESIVE COMPLIES WITH FDA REGULATIONS (21 CFR 175).
9. ALL RUBBER & RUBBER-LIKE MATERIALS USED AS PRODUCT CONTACT SURFACES COMPLY WITH ALL APPLICABLE FDA & 3A STANDARDS.
10. PATENT NUMBER US-6193409 B.
11. CUSTOMER MUST SUPPLY A MINIMUM OF 25 PSI FOR PROPER OPERATION OF SIDE SPRAY CIP ASSY.

**MUELLER**<sup>®</sup>

P.O. Box 828 • Springfield, Missouri 65801-0828, U.S.A.  
Phone: (417) 575-9000 • 1-800-MUELLER • Fax: (417) 575-9669  
[www.muel.com](http://www.muel.com) • E-mail: [processing@muel.com](mailto:processing@muel.com)