

9-16 4 x 8 Tankless Falling Film Chiller Submittal



Model No.: _____

Refrigerant Type: _____

Evaporator Temp.: _____

Btuh Capacity: _____

No. of Plates: _____

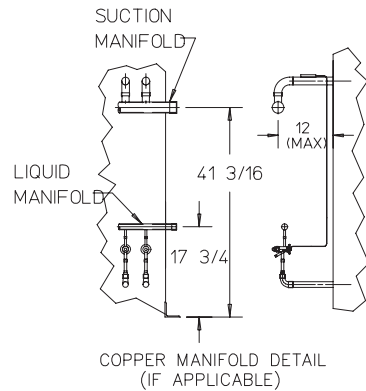
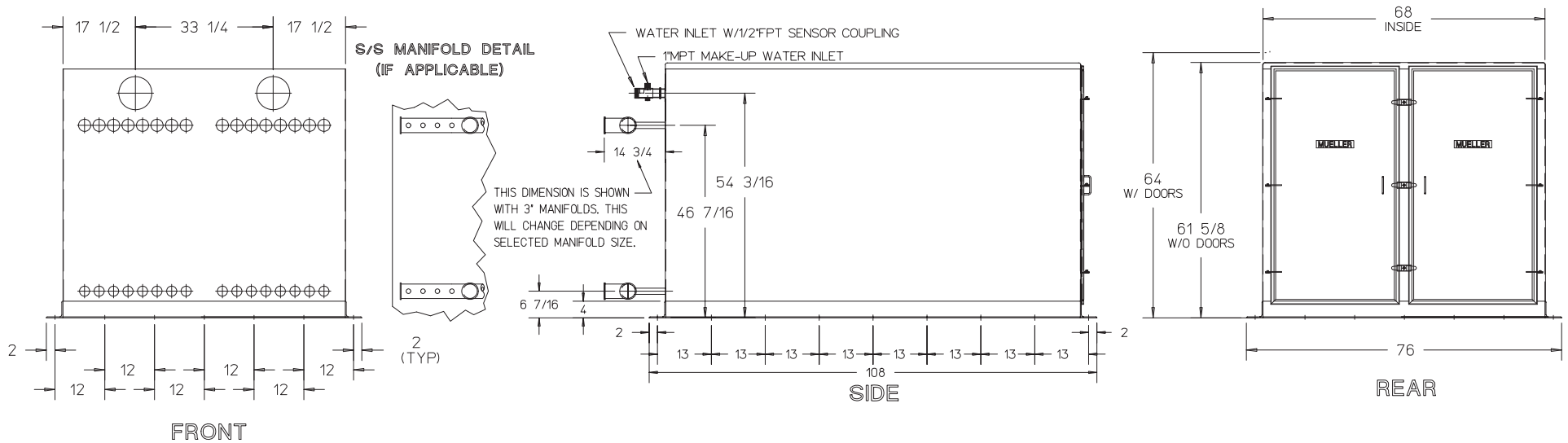

	S/S MAT'L TYPE	MAX SHIP WEIGHT (LBS)	MAX OPERATING WEIGHT (LBS)
R-22	304	2,235	2,331
R-717	304	2,235	2,283

NOTES:

- DO NOT FABRICATE FROM THIS DRAWING. ALL DIMENSIONS ARE SUBJECT TO CHANGE WITHOUT NOTICE.
- ALL DIMENSIONS ARE IN INCHES UNLESS SPECIFIED OTHERWISE.
- (9) NINE FOOT SERVICE SPACE REQUIRED, AT REAR OF FALLING FILM CHILLER ASSEMBLY TO PULL DISTRIBUTION PAN AND TEMP-PLATES.
- PAUL MUELLER COMPANY IS NOT RESPONSIBLE FOR CORROSION OR SUITABILITY FOR USE OF ANY MATERIAL IN ANY PARTICULAR APPLICATION. THE CORROSION RESISTANCE AND SUITABILITY FOR USE OF A MATERIAL IS DEPENDENT ON OPERATING ENVIROMENT AND CONDITIONS, CLEANING PRACTICES AND MANY OTHER FACTORS BEYOND THE CONTROL OF THE EQUIPMENT FABRICATOR. THE USER OF THE EQUIPMENT BEARS TOTAL RESPONSIBILITY FOR CORROSION OR SUITABILITY FOR USE OF ALL MATERIALS IN THEIR PARTICULAR APPLICATION.